

Challenges and Opportunities of Gas Flow Measurement and Ventilator Testing

By: Daniel Benz



Welcome



Daniel Benz
Managing Director
IMT Analytics Inc.



Poll



Do you do ventilator or
anesthesia machine testing?

Gas Flow Measurement and Ventilator Testing



Challenges

1. Complex and unclear measurement setups
2. Ensuring that your gas flow analyzer is set-up correctly
3. Understanding the test sequence and valid ranges defined by the manufacturer

Challenge 1



Complex and unclear
measurement setups

Example 1

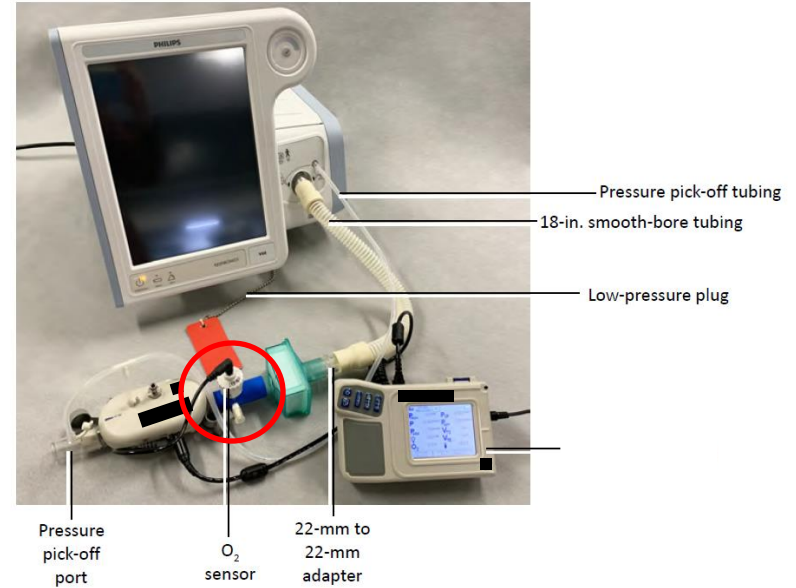
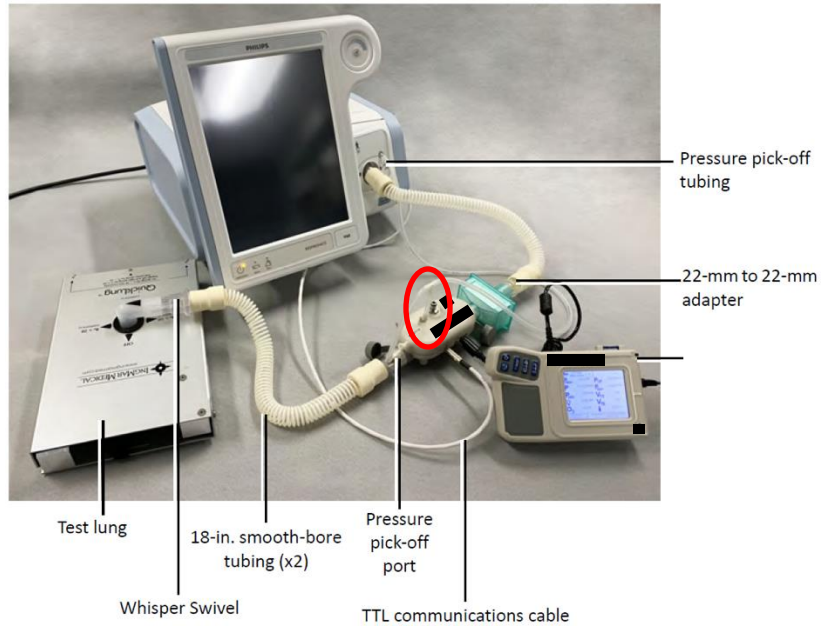

Example 2

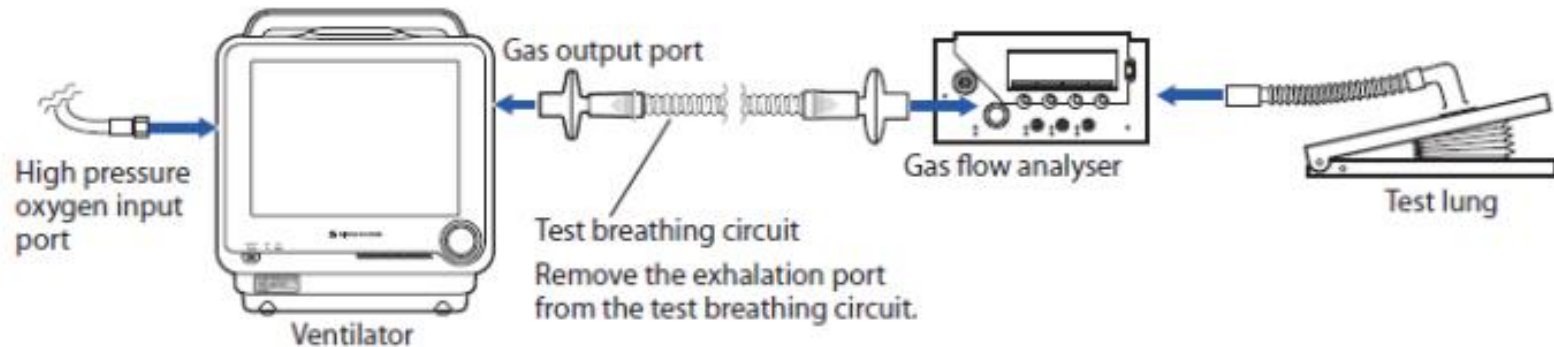

Example 3

4. Tee in a calibrated flow/volume analyzer into the patient circuit and verify V_{ti} is displayed on the analyzer.

Opportunities

- Understand your gas flow analyzer

Depending on the analyzer you use, your measurement setup can look very different.

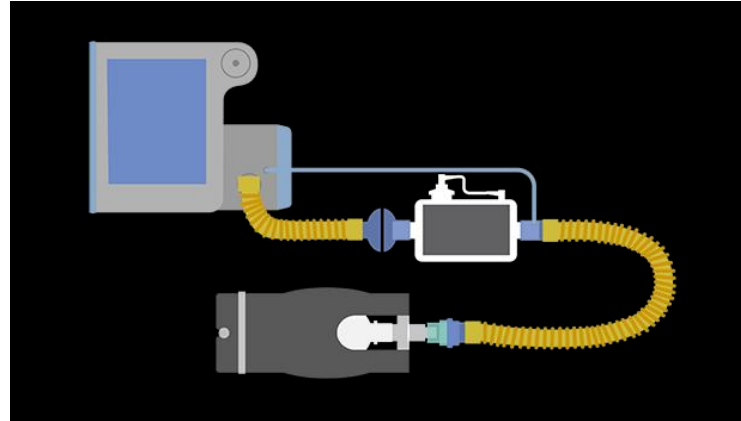
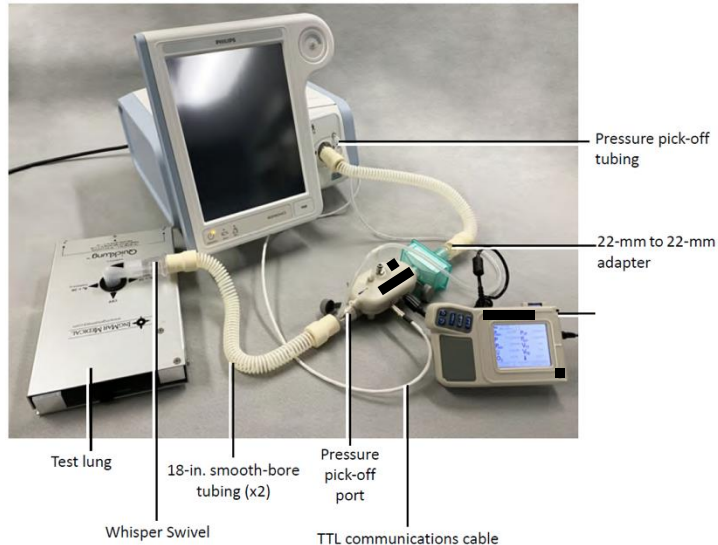

Opportunities

- Select a gas flow analyzer that allows simple setups

All-in-one devices allow simpler measurement setups.

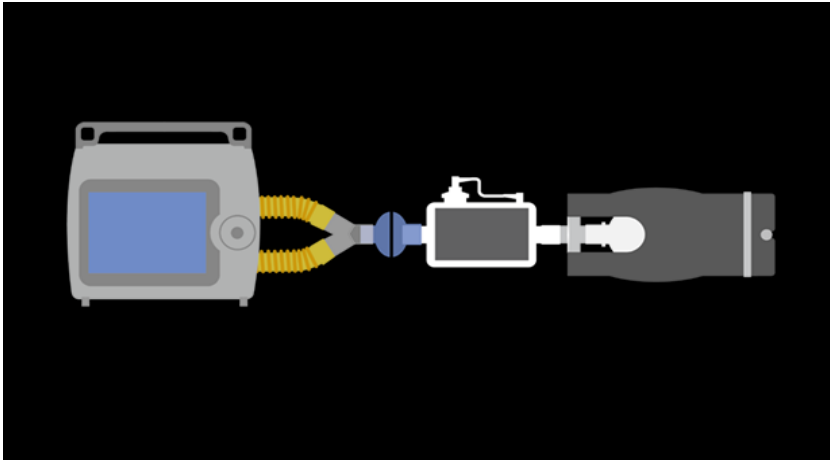

This helps minimizing the risk of measurement errors caused by inappropriate setups.

Challenge 2



Ensuring your gas flow analyzer is set-up correctly

Critical Settings on Gas Flow Analyzers

- Gas Type
 - Gas Standard
 - Trigger Settings
 - Measurement Parameters
- for all flow and volume measurements
- when measuring breath-based parameters such as PEEP, Rate or V_{Ti}

Gas Type and Gas Standard

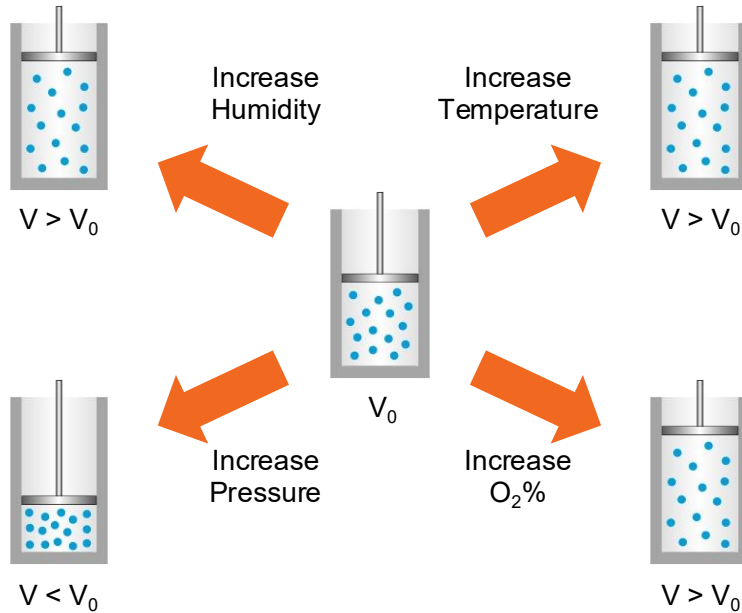

The same number of gas molecules occupy a different amount of volume depending on gas conditions and characteristics

Gas Type and Gas Standard

- Gas density
- Gas viscosity
- Gas viscosity coefficient
- Differential pressure over the flow channel resistance
- Gas pressure
- Gas temperature
- Gas humidity
- Gas Oxygen concentration

Gas Type setting

typically measured by the device

Gas Flow Analyzer
calculates actual
flow rate



This process is considered
gas flow measurement

Some depend on the used measurement principle. Example shown for differential pressure method.

Gas Type and Gas Standard

Gas flow measurement
is based on the actual
gas conditions

This is called **Gas Standard**
ATP = **A**ctual **T**emperature
and **P**ressure

Conversion



Standardization

To make flow rates comparable –
independent from gas conditions
– the flow rate can be converted
and displayed in a **Gas Standard**,
at standardized gas conditions



This process is
considered **gas**
flow displaying

Gas Type and Gas Standard

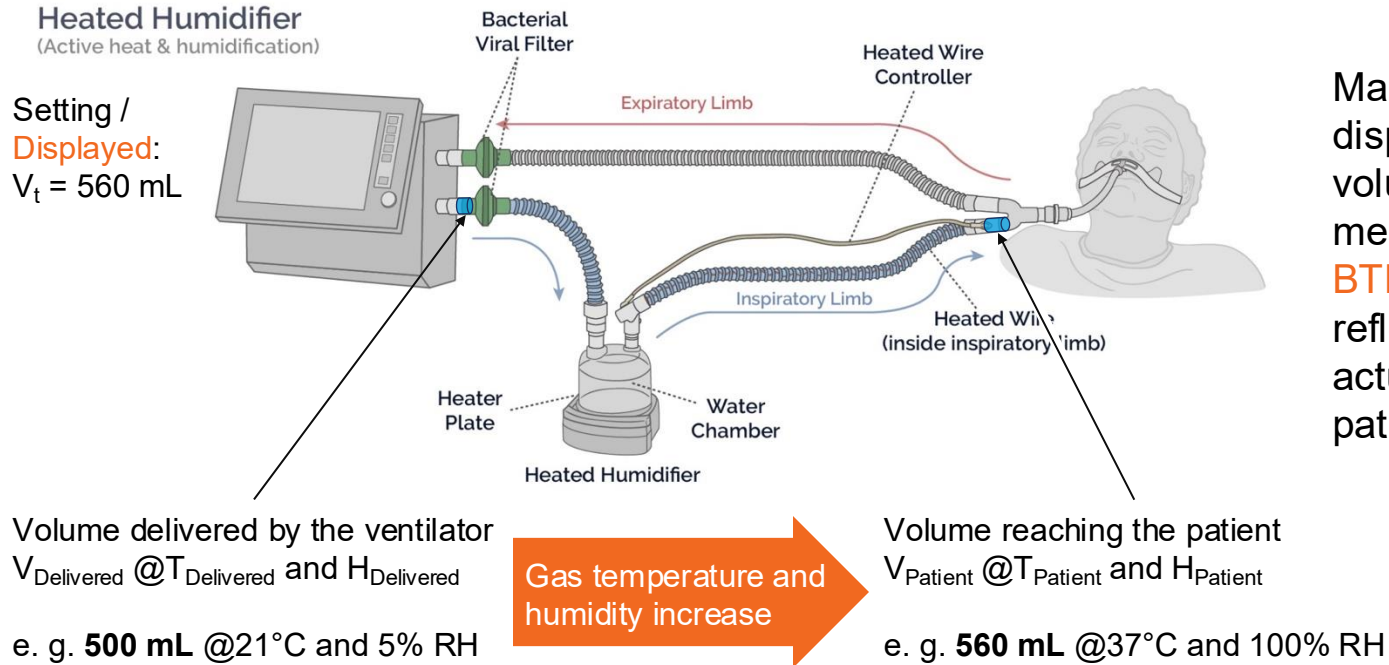

Many ICU ventilators display flow and volume settings and measurements in the **BTPS gas standard** to reflect volumes actually reaching the patient

Gas Type and Gas Standard

Typical test / calibration setup:

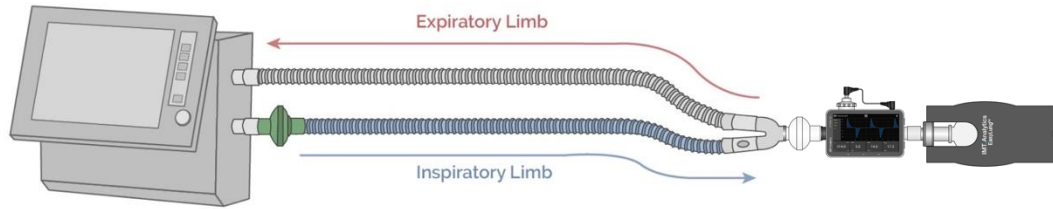

Setting /
Displayed:
 $V_{ti} = 560 \text{ mL}$



Why?

Measured:
 $V_{ti} = 500 \text{ mL}$



Gas Type and Gas Standard

Typical test / calibration setup:

Setting /
Displayed:
 $V_t = 560 \text{ mL}$

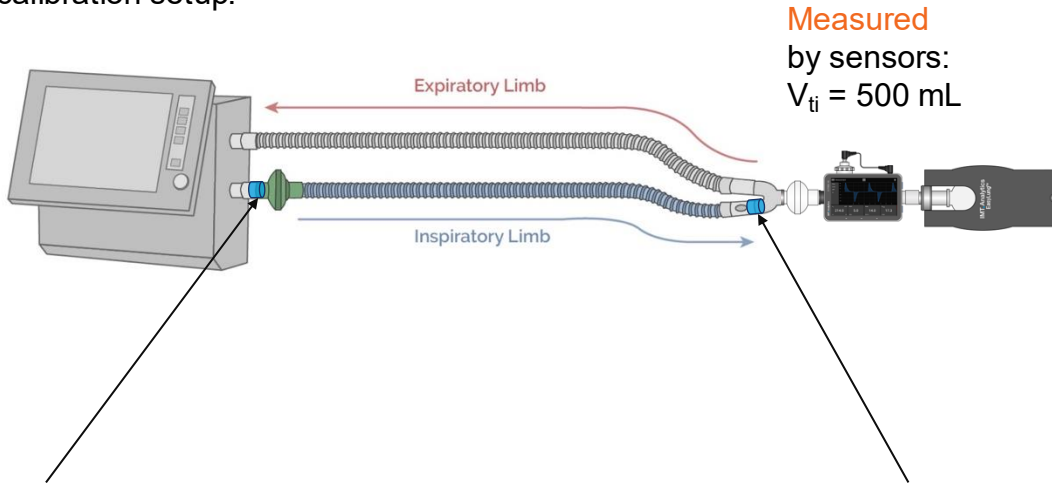

Comparing flow and volumes displayed in different gas standards can lead to **significant errors**

Volume delivered by the ventilator
 $V_{\text{Delivered}} @ T_{\text{Delivered}}$ and $H_{\text{Delivered}}$
e. g. **500 mL @21°C** and 5% RH

No change of gas
conditions

Volume measured by analyzer
 $V_{\text{Measured}} @ T_{\text{Measured}}$ and H_{Measured}
e. g. **500 mL @21°C** and 5% RH

Gas Type and Gas Standard

It is crucial the Gas Flow Analyzer and the device under test (DUT) are **using the same Gas Standard**

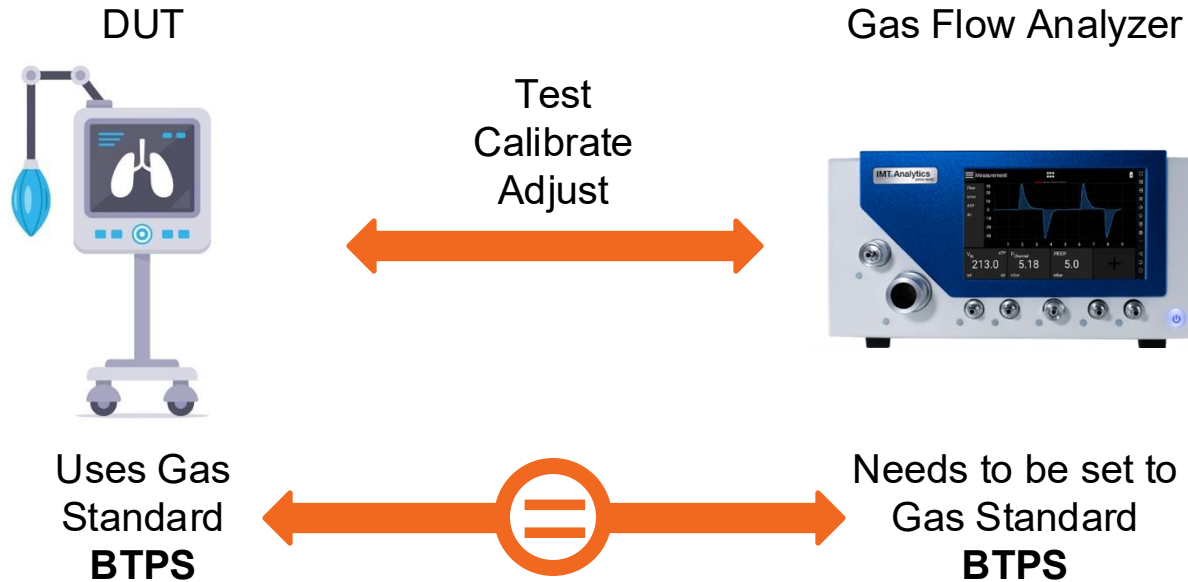

Gas Type and Gas Standard

Typical test / calibration setup:

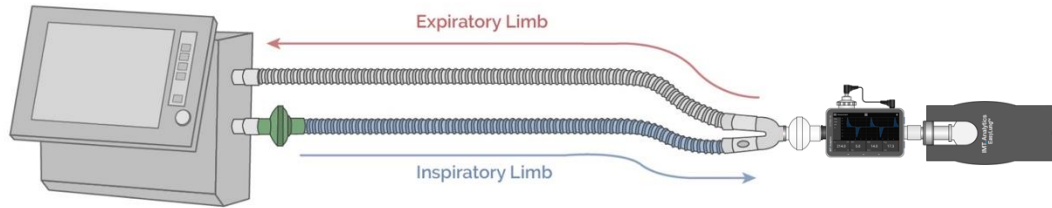

Setting /
Displayed:
 $V_{ti} = 560 \text{ mL}$
Delivered:
 $V_{ti} = 500 \text{ mL}$



Measured by
sensors:
 $V_{ti} = 500 \text{ mL}$
Displayed for
monitoring:
 $V_{ti} = 560 \text{ mL}$

Trigger Settings

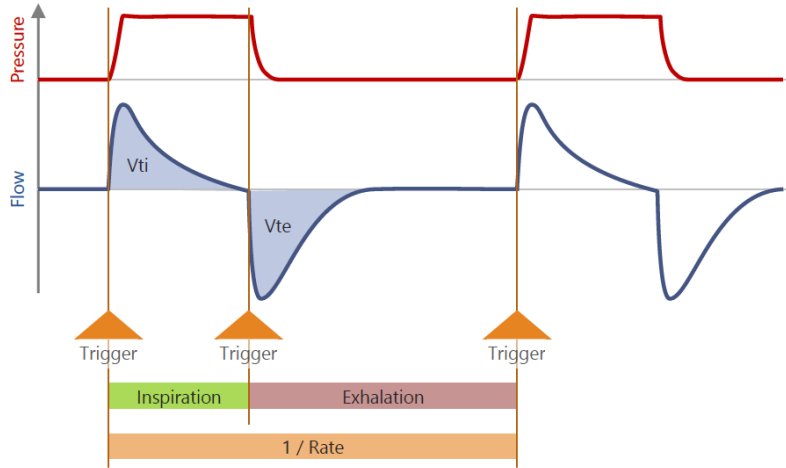

Trigger settings are used by Gas Flow Analyzers to **identify the start** of an inspiration phase **and the transition** from inspiration to exhalation



Calculation of **breath-based parameters**

V_{ti} , V_{te} , Rate, I:E, PEEP, ...

Trigger settings on the Gas Flow Analyzer have nothing in common with the spontaneous breathing trigger settings of a ventilator!

Trigger Settings

The accuracy of several **breath-based parameters** depend on correct Trigger Settings

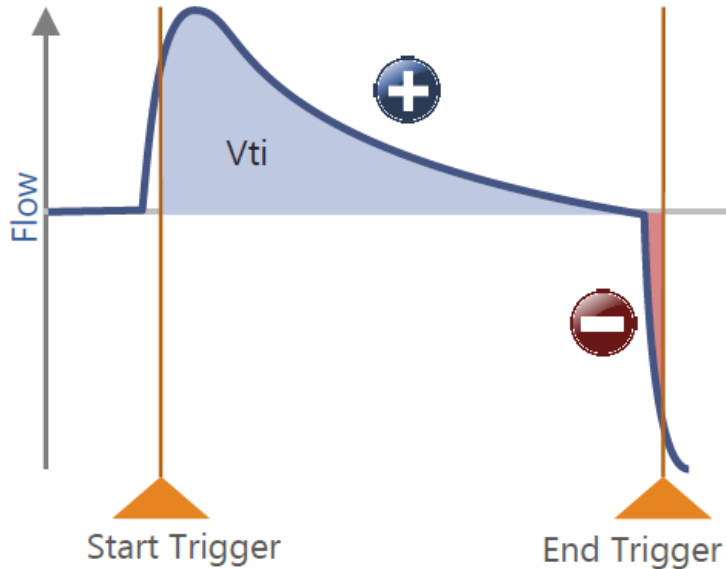

$$Vti = \left| \int_{Start\ Trigger}^{End\ Trigger} Flow(t) \times dt \right|$$

Trigger Settings

1

Trigger Source

Defines the physical interface for the trigger



2

Trigger Signal

Defines the signal to be watched

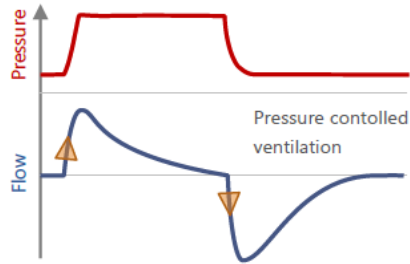

3

Trigger Level

Defines the threshold value and signal edge to activate the trigger

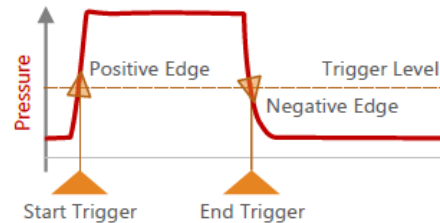

Trigger Settings

A good trigger signal allows trigger levels to be set as close as possible to the timing of the real breath phase change.

Is this a good trigger signal?

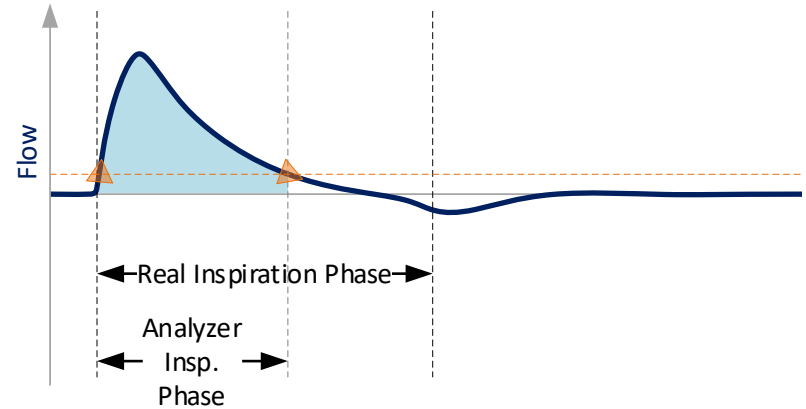
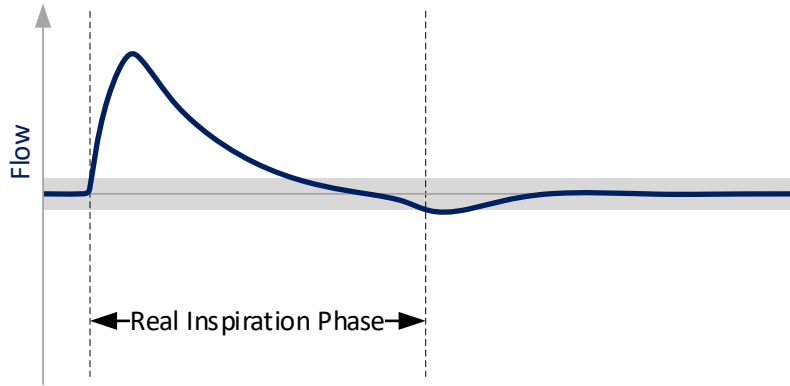

Trigger Settings

A good trigger signal allows trigger levels to be set as close as possible to the timing of the real breath phase change.

How about this one?

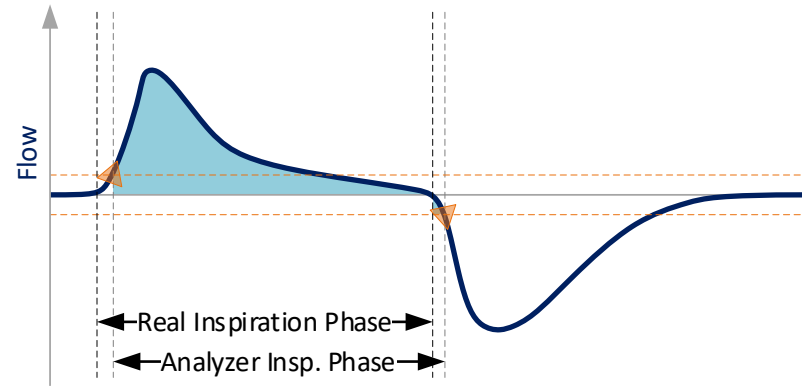
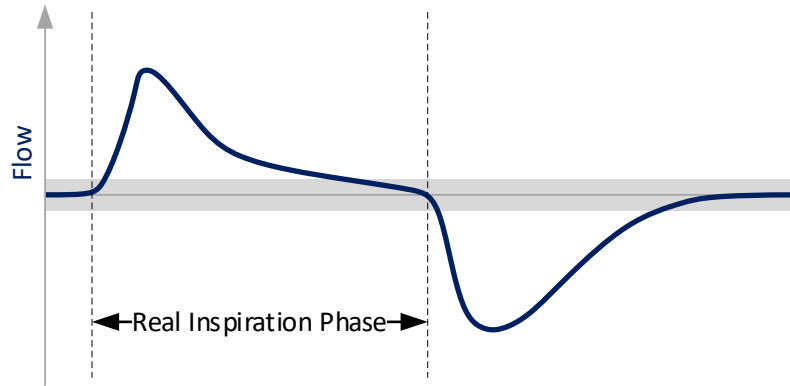

Trigger Settings

A good trigger signal allows trigger levels to be set as close as possible to the timing of the real breath phase change.

What about this one?

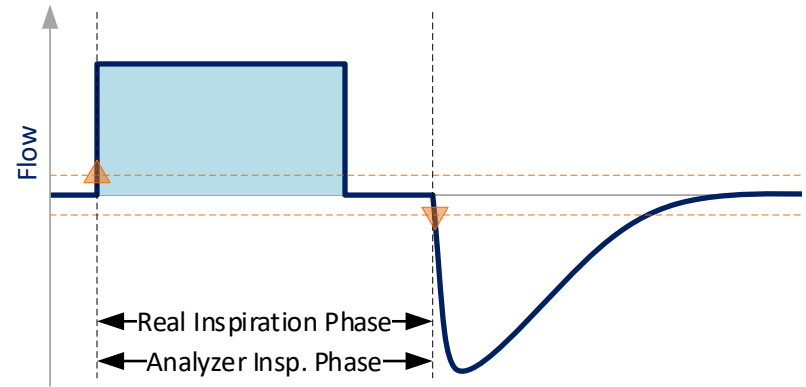
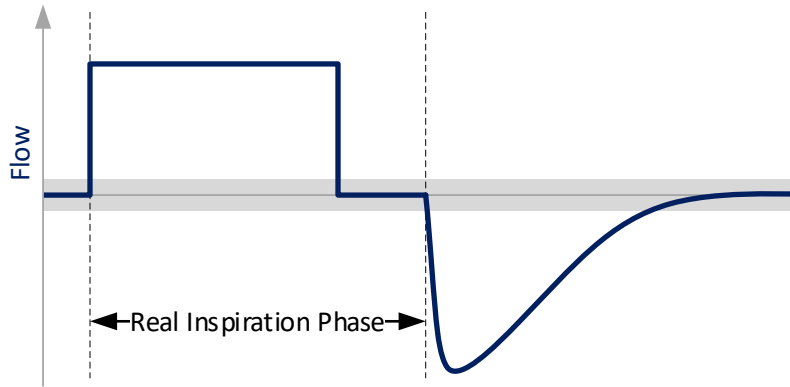

Lesson learned: A good trigger signal has steep rising or falling slopes at the beginning of each breath phase

Trigger Settings

Flow triggers work best for most adult ventilation measurements, in both pressure- and volume-controlled ventilation thanks to the sharp rise and fall of the flow signal.

Pressure / Volume Controlled Ventilation

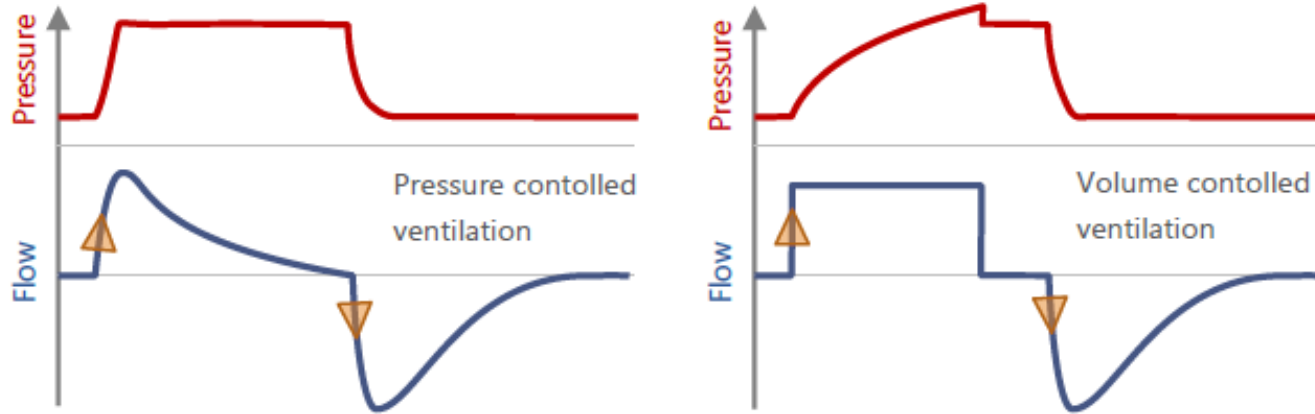

Trigger Settings

Typical Trigger Settings that work best for most adult ventilation measurements are:

- Trigger source: Flow channel
- Trigger signal: Flow
- Trigger level:
 - Start: +3 L/min on rising edge
 - End: -3 L/min on falling edge

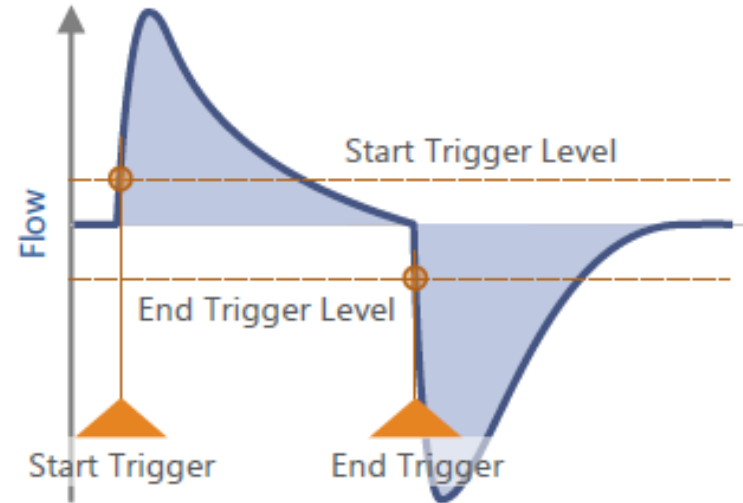

Good news: These or very similar values are typically the default trigger settings of gas flow analyzers

Trigger Settings

Challenge without negative flow through the analyzer

Ventilator in BiPAP mode

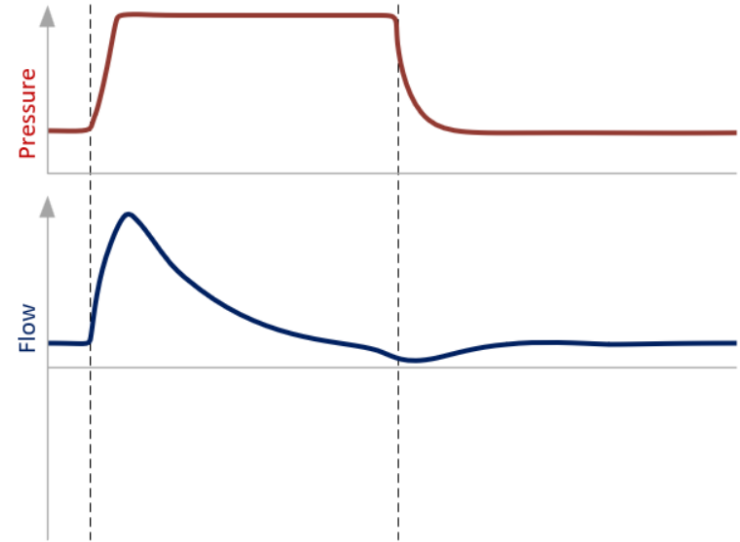
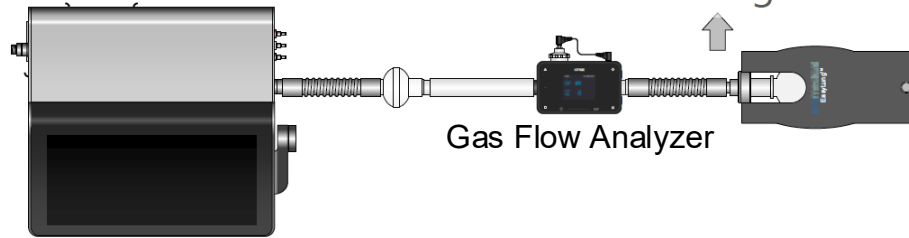

Trigger Settings

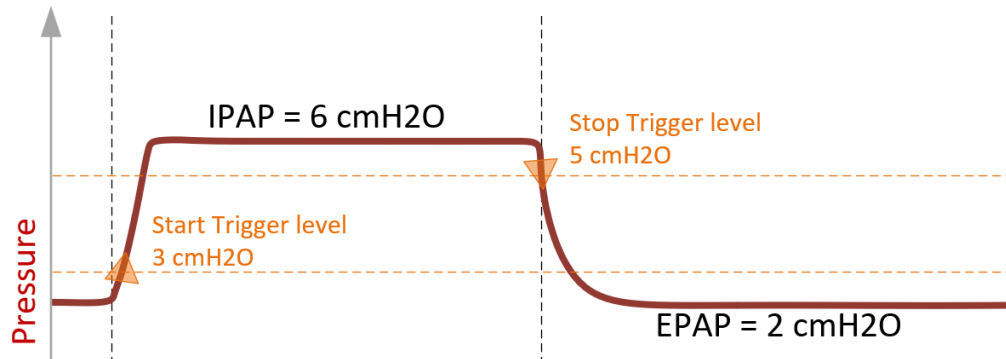
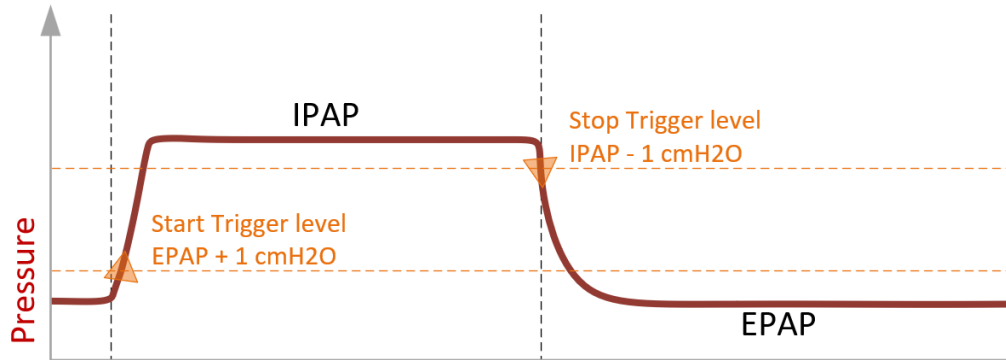

Your gas flow analyzer's measurement display after changing the settings on the ventilator to IPAP of 8 cmH2O and EPAP to 4 cmH2O:

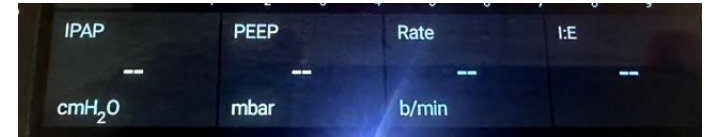

Trigger Settings

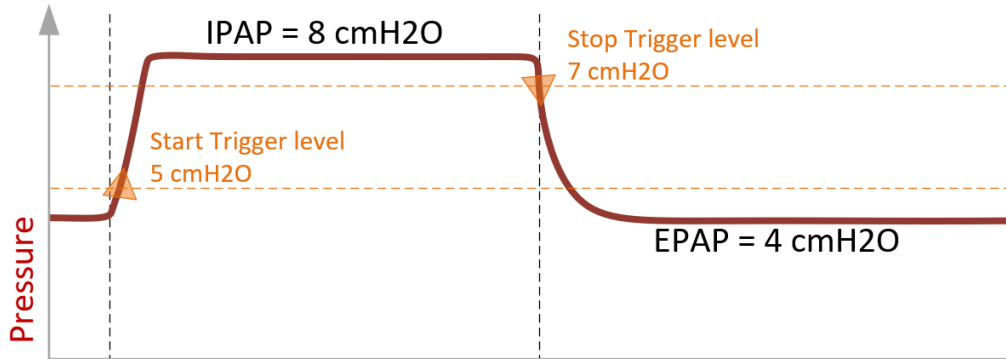
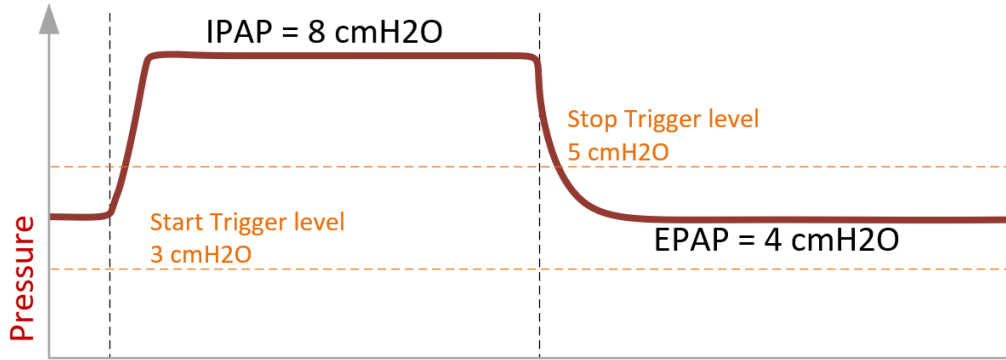

Trigger Settings

Trigger Delay

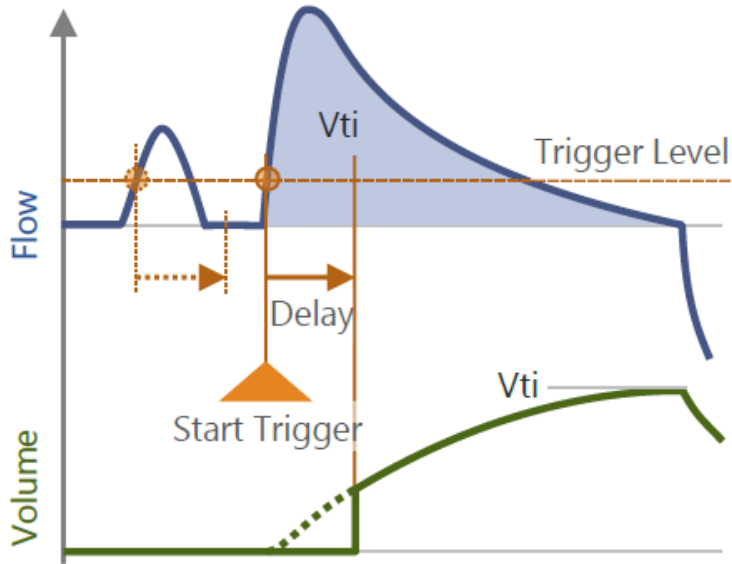

Baseflow

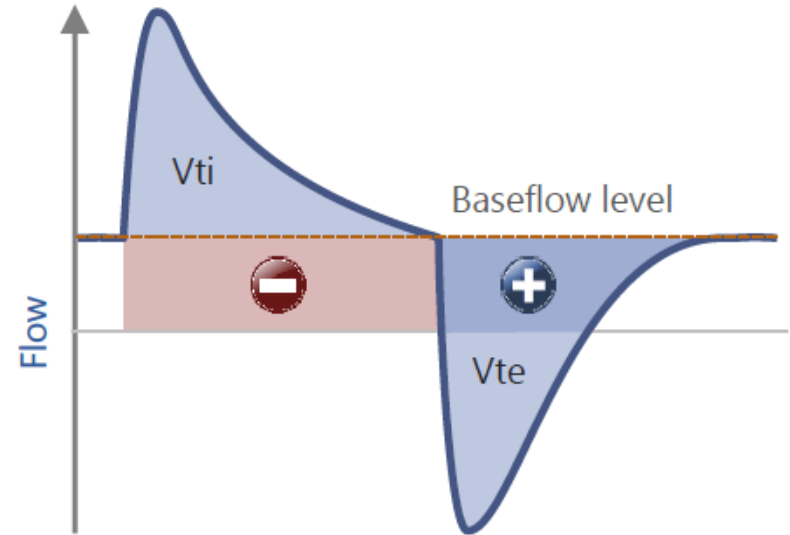

Measurement Parameters

The desired Measurement Parameters should be easily visible and configured in the unit matching the ventilator's monitoring.

Measurement				33%			
Vi	ATP	P _{Channel}	V _{ti}	ATP	O ₂		
2996.0		11.9	214.0		21.0		
l/min	Air	mbar	ml	Air	%		
PEEP		P _{Plateau}	P _{Peak}		Rate		
5.0		17.1	17.3		14.0		
mbar		mbar	mbar		b/min		
I:E		Ti	Te				
0.5:1		1.70	3.40				+
		s	s				

Opportunities

- Create and use profiles

The latest generation of gas flow analyzers offer the possibility to create application specific profiles, effectively storing all critical settings discussed:

- Gas type and gas standard
- Trigger settings
- Measurement screens customization

This helps minimizing the risk of inappropriate settings and reading errors.

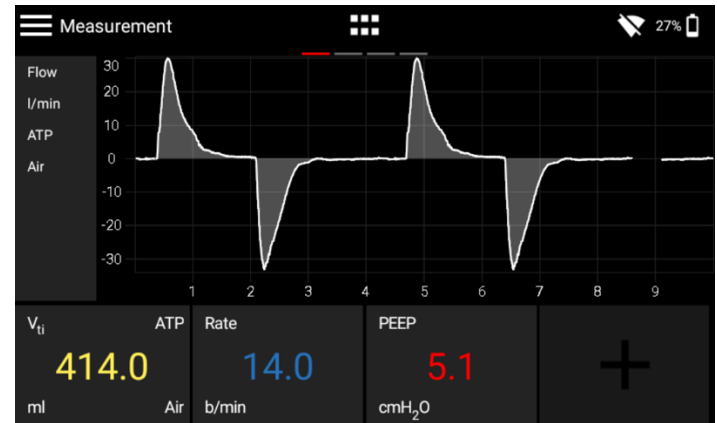

Opportunities

- Use advanced aids and automation features

Modern gas flow analyzers are equipped with advanced aids and features to help you find suitable trigger settings, such as:

- On-device waveform analysis
- Graphical trigger indications and setting support
- Automatic trigger detection

This helps finding the best possible trigger settings allowing the highest accuracy in measuring breath-based parameters.

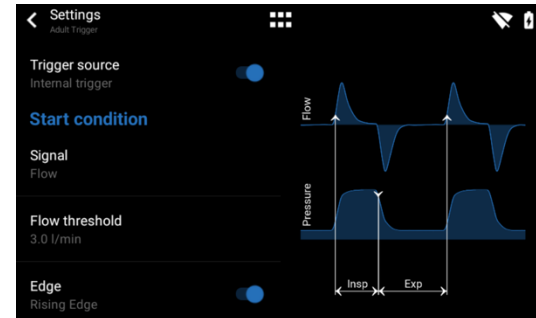

Poll



Have you faced any of the challenges discussed so far, too?

Challenge 3



Understand the test sequence and valid ranges defined by the manufacturer

Example 1

11. Set ventilator pressure values and verify that they correspond to pressure measurements:

NOTE

If the pressure accuracy test fails at 0 cmH₂O, restart the ventilator in ventilation mode. Once the ventilator passes POST, repeat the pressure accuracy test.

Set Pressure to:	Verify that the Avg Machine and Avg Proximal displays read:
0 cmH ₂ O	-1.00 to 1.00 cmH ₂ O (software version 3.00 and earlier) -3.5 to 5.5 cmH ₂ O (software version 3.10 and later)
Set Pressure to:	Verify that the analyzer, Avg Machine, and Avg Proximal displays read (see section 9.7.1 for example test calculations):
10 cmH ₂ O	Analyzer and Avg Machine: 7.6 to 12.4 cmH ₂ O (analyzer reading + Avg Machine zero offset)
	Avg Proximal: Lower limit = (analyzer reading x 0.96) - 2 Upper limit = (analyzer reading x 1.04) + 2 (Avg Proximal reading - Avg Proximal zero offset)
35 cmH ₂ O	Analyzer and Avg Machine: 31.6 to 38.4 cmH ₂ O (analyzer reading + Avg Machine zero offset)
	Avg Proximal: Lower limit = (analyzer reading x 0.96) - 2 Upper limit = (analyzer reading x 1.04) + 2 (Avg Proximal reading - Avg Proximal zero offset)
60 cmH ₂ O	Analyzer and Avg Machine: 55.6 to 64.4 cmH ₂ O (analyzer reading + Avg Machine zero offset)
	Avg Proximal: Lower limit = (analyzer reading x 0.96) - 2 Upper limit = (analyzer reading x 1.04) + 2 (Avg Proximal reading - Avg Proximal zero offset)

9.7.1 Pressure Accuracy Test Example

Zero offset readings:

- Avg Machine reading at 0 cmH₂O = (-0.24)
- Avg Proximal reading at 0 cmH₂O = (-0.21)

Analyzer and Avg Machine tolerances and calculations:

At 10 cmH₂O (7.6 to 12.4 cmH₂O):

- Analyzer reading at 10 cmH₂O = 10.23
- Avg Machine reading at 0 cmH₂O = (-0.24)
- Calculation (analyzer reading plus Avg Machine zero offset):
10.23 + (-0.24) = 9.99 cmH₂O

At 35 cmH₂O (31.6 to 38.4 cmH₂O):

- Analyzer reading at 35 cmH₂O = 35.23
- Avg Machine reading at 0 cmH₂O = (-0.24)
- Calculation (analyzer reading plus Avg Machine zero offset):
35.23 + (-0.24) = 34.99 cmH₂O

At 60 cmH₂O (55.6 to 64.4 cmH₂O):

- Analyzer reading at 60 cmH₂O = 60.26
- Avg Machine reading at 0 cmH₂O = (-0.24)
- Calculation (analyzer reading plus Avg Machine zero offset):
60.26 + (-0.24) = 60.02 cmH₂O

Avg Proximal tolerances and calculations:

At 10 cmH₂O (see lower and upper limits):

- Analyzer reading at 10 cmH₂O = 10.23
- Avg Proximal reading at 10 cmH₂O = 10.04
- Avg Proximal reading at 0 cmH₂O = (-0.21)
- Tolerances:
 - Lower limit = (analyzer reading x 0.96) - 2 = (10.23 x 0.96) - 2 = 7.82
 - Upper limit = (analyzer reading x 1.04) + 2 = (10.23 x 1.04) + 2 = 12.64
- Calculation (Avg Proximal reading - Avg Proximal zero offset): 10.04 - (-0.21) = 10.25

At 35 cmH₂O (see lower and upper limits):

- Analyzer reading at 35 cmH₂O = 35.23
- Avg Proximal reading at 35 cmH₂O = 35.05
- Avg Proximal reading at 0 cmH₂O = (-0.21)
- Tolerances:
 - Lower limit = (analyzer reading x 0.96 - 2) = (35.23 x 0.96) - 2 = 31.82
 - Upper limit = (analyzer reading x 1.04 + 2) = (35.23 x 1.04) + 2 = 38.64
- Calculation (Avg Proximal reading - Avg Proximal zero offset): 35.05 - (-0.21) = 35.26

At 60 cmH₂O (see lower and upper limits):

- Analyzer reading at 60 cmH₂O = 60.26
- Avg Proximal reading at 60 cmH₂O = 60.06
- Avg Proximal reading at 0 cmH₂O = (-0.21)
- Tolerances:
 - Lower limit = (analyzer reading x 0.96) - 2 = (60.26 x 0.96) - 2 = 55.85
 - Upper limit = (analyzer reading x 1.04) + 2 = (60.26 x 1.04) + 2 = 64.67
- Calculation (Avg Proximal reading - Avg Proximal zero offset): 60.06 - (-0.21) = 60.27

Example 1

- Set ventilator pressure values and verify that they correspond to pressure measurements:

NOTE

If the pressure accuracy test fails at 0 cmH₂O, restart the ventilator in ventilation mode. Once the ventilator passes POST, repeat the pressure accuracy test.

Set Pressure to:	Verify that the Avg Machine and Avg Proximal displays read:
0 cmH ₂ O	-1.00 to 1.00 cmH ₂ O (software version 3.00 and earlier) -3.5 to 5.5 cmH ₂ O (software version 3.10 and later)
Set Pressure to:	Verify that the analyzer, Avg Machine , and Avg Proximal displays read (see section 9.7.1 for example test calculations):
10 cmH ₂ O	Analyzer and Avg Machine : 7.6 to 12.4 cmH ₂ O (analyzer reading + Avg Machine zero offset) Avg Proximal : Lower limit = (analyzer reading x 0.96) - 2 Upper limit = (analyzer reading x 1.04) + 2 (Avg Proximal reading - Avg Proximal zero offset)
35 cmH ₂ O	Analyzer and Avg Machine : 31.6 to 38.4 cmH ₂ O (analyzer reading + Avg Machine zero offset) Avg Proximal : Lower limit = (analyzer reading x 0.96) - 2 Upper limit = (analyzer reading x 1.04) + 2 (Avg Proximal reading - Avg Proximal zero offset)
60 cmH ₂ O	Analyzer and Avg Machine : 55.6 to 64.4 cmH ₂ O (analyzer reading + Avg Machine zero offset) Avg Proximal : Lower limit = (analyzer reading x 0.96) - 2 Upper limit = (analyzer reading x 1.04) + 2 (Avg Proximal reading - Avg Proximal zero offset)

Necessary procedure for each scale point:

- Read pressure value on the analyzer
- Judge if the analyzer reading is within the valid range
- Calculate **Avg Machine**
- Judge if the calculated value for **Avg Machine** is within the valid range
- Read **Avg Proximal** on the ventilator
- Calculate **Avg Proximal**
- Calculate the lower tolerance limit for **Avg Proximal**
- Calculate the upper tolerance limit for **Avg Proximal**
- Judge if the calculated value for **Avg Proximal** is within the calculated valid range

Example 2

- 1 Set the value of the Flow to "180" L/min and touch [Start].

The gas flow is output from the ventilator.

Flow bar
Tap [◀] or [▶] to change the Flow value.

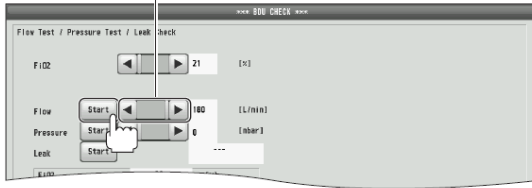

- 2 Confirm that the measured flow value (Flow H) of the gas flow analyzer is within the specified range shown as flow analyzer reading.
 - Flow analyzer reading: 153 to 207 (L/min) A

Note: If the measured flow value (Flow H) is fluctuating, estimate the median from the upper and lower values of the measured value. Confirm that the estimated value is within the specified range.
- 3 Confirm that the Output Flow value on the BDU CHECK window is within the specified range shown as ventilator reading.
 - Ventilator reading: $A \pm (0.5 + A \times 15\%) \times 1000$ (mL/min)



Refer to the reference table to easily determine that the measured value is within the specified range.

"Reference Table for Test Specification Range" (p. 263)

- Output Flow: "Flow (Setting: 180 L/min)" (p. 265)

Note: If the Output Flow value is fluctuating, estimate the median from the upper and lower values of the measured value. Confirm that the estimated value is within the specified range.

Necessary procedure for each scale point:

1. Read the value on the analyzer
2. If value is fluctuating, estimate the median reading
3. Judge if the analyzer reading is within the valid range
4. Calculate the lower tolerance limit for the output flow reading of the ventilator using the reading of the analyzer
5. Calculate the upper tolerance limit for the output flow reading of the ventilator using the reading of the analyzer
6. Judge if the reading of the ventilator is within the calculated valid range

Opportunities

- Use guided testing apps and test sequence features

Advanced state-of-the-art gas flow analyzers offer ready-to-use, ventilator-specific testing apps that:

- Guide you through the procedure as per the manufacturer's specification
- Take and interpret measurements automatically
- Create a test report with all the results that can then be saved as a PDF file

This helps to make testing workflows more efficient and to eliminate risks of measurement or transcription errors.

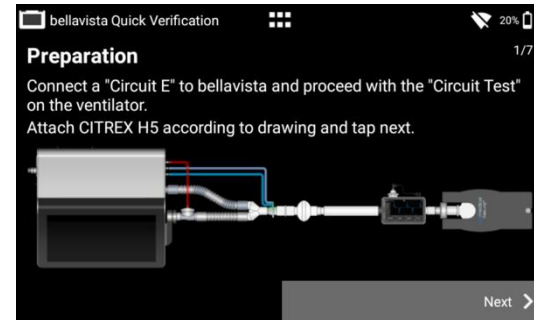

bellavista Quick Verification 3/7

Verification in progress

Wait until values are stable

Parameter	Measured	Expected	Result
P _{Peak}	17.3 mbar	14 .. 20 mbar	✓
PEEP	5.0 mbar	4 .. 6 mbar	✓
Rate	14.0 bpm	11 .. 13 bpm	✗
FIO ₂	21.0 %	19 .. 23 %	✓

< Previous Next >

Key Takeaways

- Ensure you understand the features of your gas flow analyzer
- Pay special attention to set-up your analyzer appropriately for your specific application
- Take advantage of advanced features of your current or future gas flow analyzer that help you in overcoming these challenges

Visit our Booth #305

We look forward to showing you how our advanced Gas Flow Analyzers can help you in overcoming these challenges

IMT.Analytics



Thank you!

